

Loading and unloading pallets close to the floor - With the 2 - 5-strand chain conveyor

- Suitable for the feeding and removal of full and empty pallets (e.g. Euro, industrial and half pallets), pallet cages, workpiece carriers and skids.
- Load capacity up to 1.500 kg.
- Available as a 2-5-strand chain conveyor.
- For manual loading of the pallets, a hand pallet truck or an electric fork lift can be used.
- The conveyor chain is guided in a plastic slide rail or optionally in a steel guide.
- The integrated tensioning station makes it easy to retension the chain.
- Adjustable uprights are used to compensate for uneven floors.
- Use at normal room temperature and down to -30 °C in the deep-freeze area
- Surface sendzimir galvanised or in your RAL colour powder-coated.
- Optionally, driven web overlaps, traversing devices, tread plates between the chain strands, end stops, ram gates, feed chutes or centring stops can be implemented.
- Special design on request.

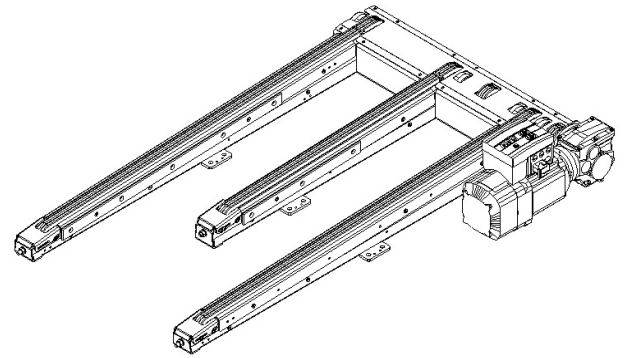
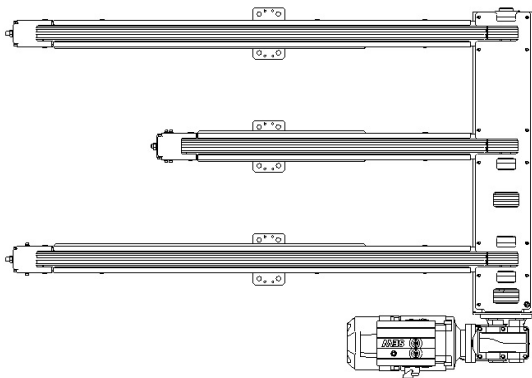
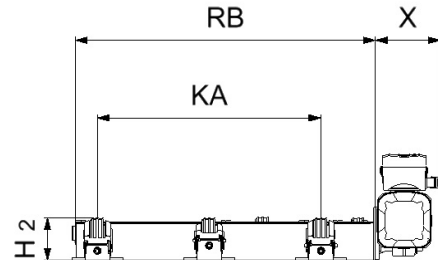
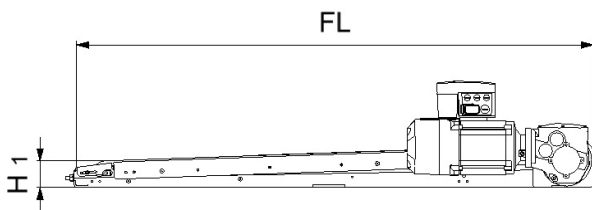

List of abbreviations

FGB	= conveyed material width	FL	= conveying length
FB	= conveying width	H_{1,2}	= frame height
RB	= frame width	FGG	= conveyed material weight per storage location
KA	= chain spacing	x	= Drive motor structure
N	= amount of of chain strands		

Standard dimensions in mm (Special versions are possible on request)

Carrying capacity in kg

Typ	Conveyed material	Chain strands	Dimensions						Max. conveyed material weight per storage location
			FB	RB	FL	KA	H ₁	H ₂	
Nr.	FGB	N	FB	RB	FL	KA	H₁	H₂	FGG
621.01	800	2	860	1000	1650 / 2150 / 2850	700	80	135 / 150 / 175	1500
621.02	800	3	860	1000	1650 / 2150 / 2850	700	80	135 / 150 / 175	1500
621.03	1000	2	1060	1200	1650 / 2150 / 2850	900	80	135 / 150 / 175	1500
621.04	1000	3	1000	1200	1650 / 2150 / 2850	900	80	135 / 150 / 175	1500
621.05	800 & 1000	5	800 / 1000	1200	1650 / 2150 / 2850	700 / 900	80	135 / 150 / 175	1500